

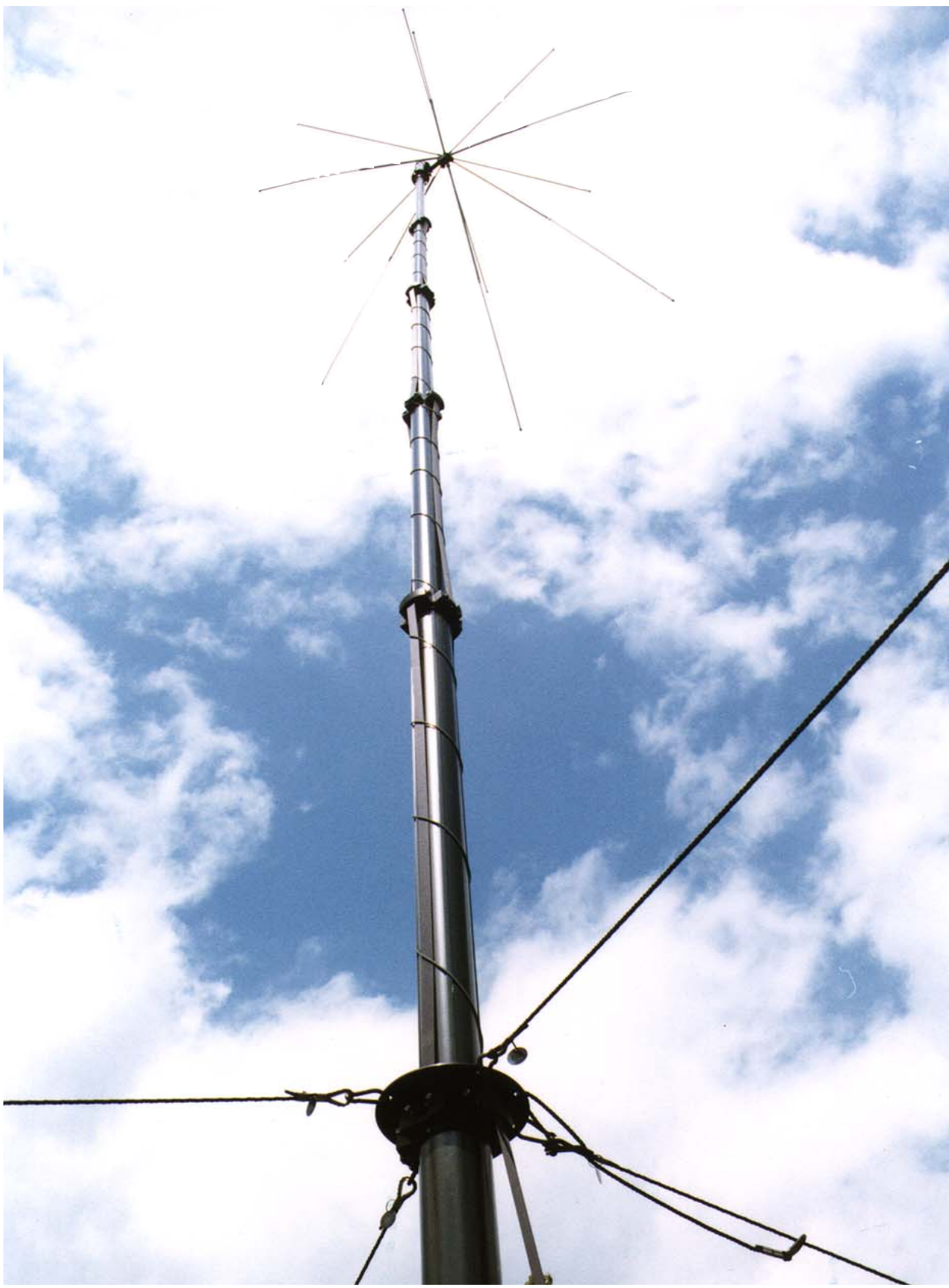

TRIVAL
antene



winch
driven

TELESCOPIC

MASTS STV

TELESCOPIC WINCH OPERATED MASTS SERIES STV DESIGNED FOR HARSH MILITARY ENVIRONMENT OPERATIONS

Telescopic winch operated masts series **STV** are designed on a basis of many years of experience in development and production of antennas and antenna masts and on a basis of knowing and considering the needs and demands of the end users in the era of modern wireless telecommunications.

The family of telescopic masts STV consists carefully selected modern materials and technologies and considerate design, functionality and simplicity of use. With all that features the family of the masts STV are suitable for use on the field as well as on the vehicles also in hardest environmental conditions.



The mast is basically composed of telescopic sections made of **composite material ("fiberglass")** by use the process of "pultrusion". By use of that technology all the fibres are placed longitudinally along the section enable excellent stability with high degree of elasticity. Certain fiberglass layer is also wounded radially during the pultrusion process enables high degree of radial hardness. The masts STV meet environmental requirements in accordance with **MIL-STD-810**.

The sections have four special **longitudinal guidways** placed equally outside and made during the process of pultrusion enable excellent guidance when raising and lowering of the masts as well as additionally longitudinal stability. The guidways ensure that the mast is **axially joined together** prevent the various sections from turning which allows us to easily turn the whole mast in the case of using directional antennas. On the end of the sections are special slide-joints made of durable polyacetal with low weight and excellent mechanical characteristics.

Erection of the mast is enabled with **removable hand operated winch** with cogwheel transmission and with system of strong polyester-aramide reinforced belts guided between the sections. During the erection we put the belt into the winch wheel and wind it with crank arm, which lifts the sections up. For lowering the mast we simply turn the crank arm in the opposite direction without any need of hand switching which is done by built-in **automatic switch mechanism**. The winch has built-in **automatic safety brake** to protect the operator in the case of heavier loads.



The telescopic mast STV has all accessories need for field erection: anchors, guying ropes (made of DYNEEMA material), hammer, etc., together with special cross-bar with eye-anchor intended to fix the mast in specific direction, the base plate with safety chain attachments and extension aluminium tube with grounding screw for antenna attachment. All the accessories are stored in separate linen bags. The mast alone has also linen cap for top sections protection.

The telescopic masts series **STV** are **applicable also for mobile use** mounted on vehicles. For this purpose a special mounting kit is available, composed of base plate element and side bracket.



STV TELESCOPIC MASTS - MOBILE MOUNTING

STV telescopic winch driven masts could be mounted on various kinds of vehicles. To ensure that the mast will be mounted properly and safely, the following facts must be taken into account:

- Two basic mobile mounting adapters are available: the STV-L/01 and STV-U/01(detailed technical drawings are available on request). Both adapters have all necessary holes and fittings made so that the masts series STV could be inserted on that adapters with the mast foot and the first guying ring plate.

- The other side of the adapters has another holes drilled and prepared to fit on special mounting bracket (not supplied!) which will fits the specific car body. The user regarding the specific car body construction must provide those adapters.

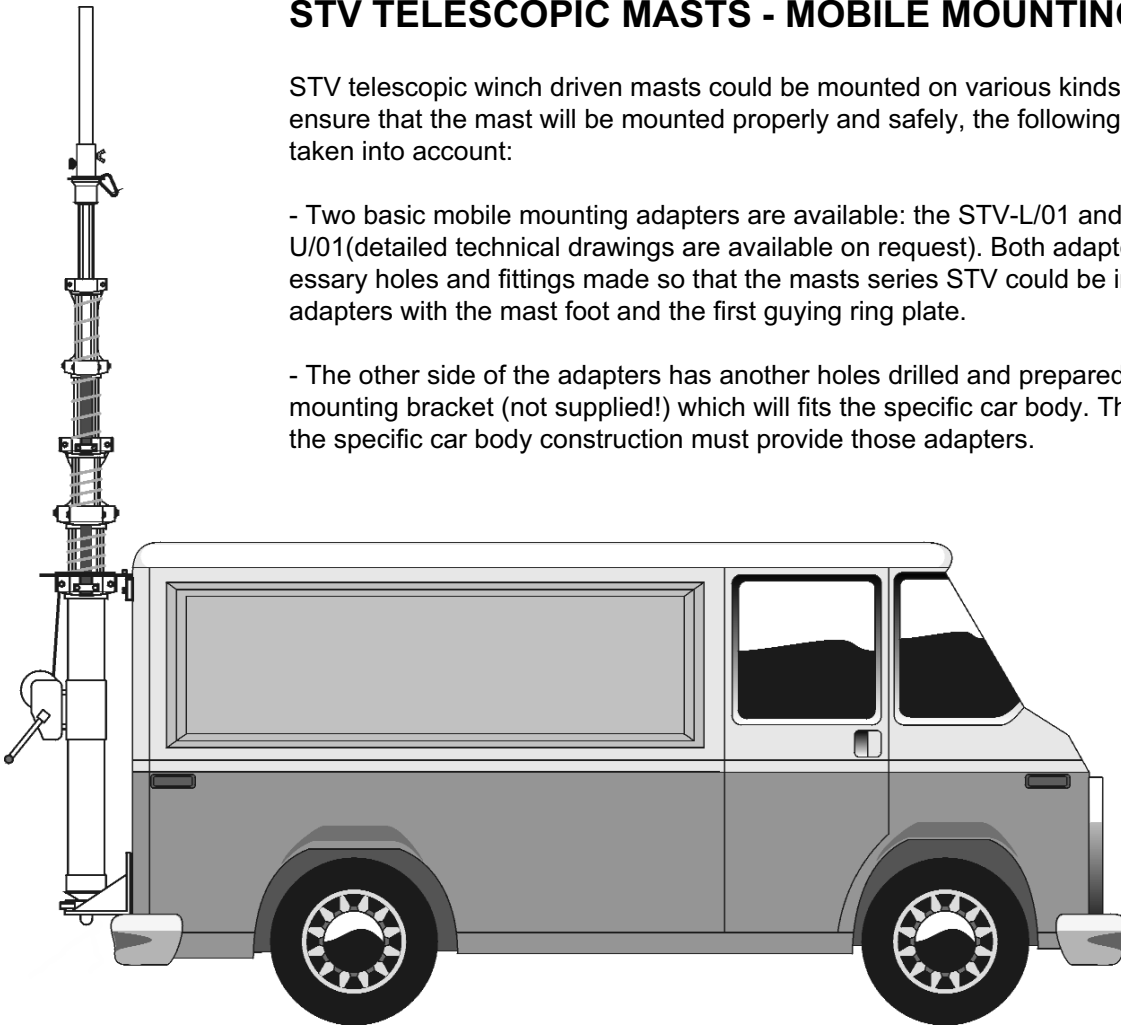

STV TELESCOPIC MASTS - SEMI-MOBILE MOUNTING

STV telescopic winch driven masts could be mounted on various kinds of vehicles. For smaller and lighter vehicles we do recommend semi-mobile mast mounting where the bottom of the mast lays on the ground. To ensure that the mast will be mounted properly and safely, the following facts must be taken into account:

- Two basic semi-mobile mounting adapters are available: the STV-U/01 and STV-BASE PLATE with three anchors and EYE BAR (detailed technical drawings are available on request). Both adapters have all necessary holes and fittings made so that the masts series STV could be inserted on that adapters with the mast foot and the first guying ring plate.

- The other side of the adapter STV-U/01 has another holes drilled and prepared to fit on special mounting bracket (not supplied!) which will fits the specific car body. The user regarding the specific car body construction must provide those adapter.

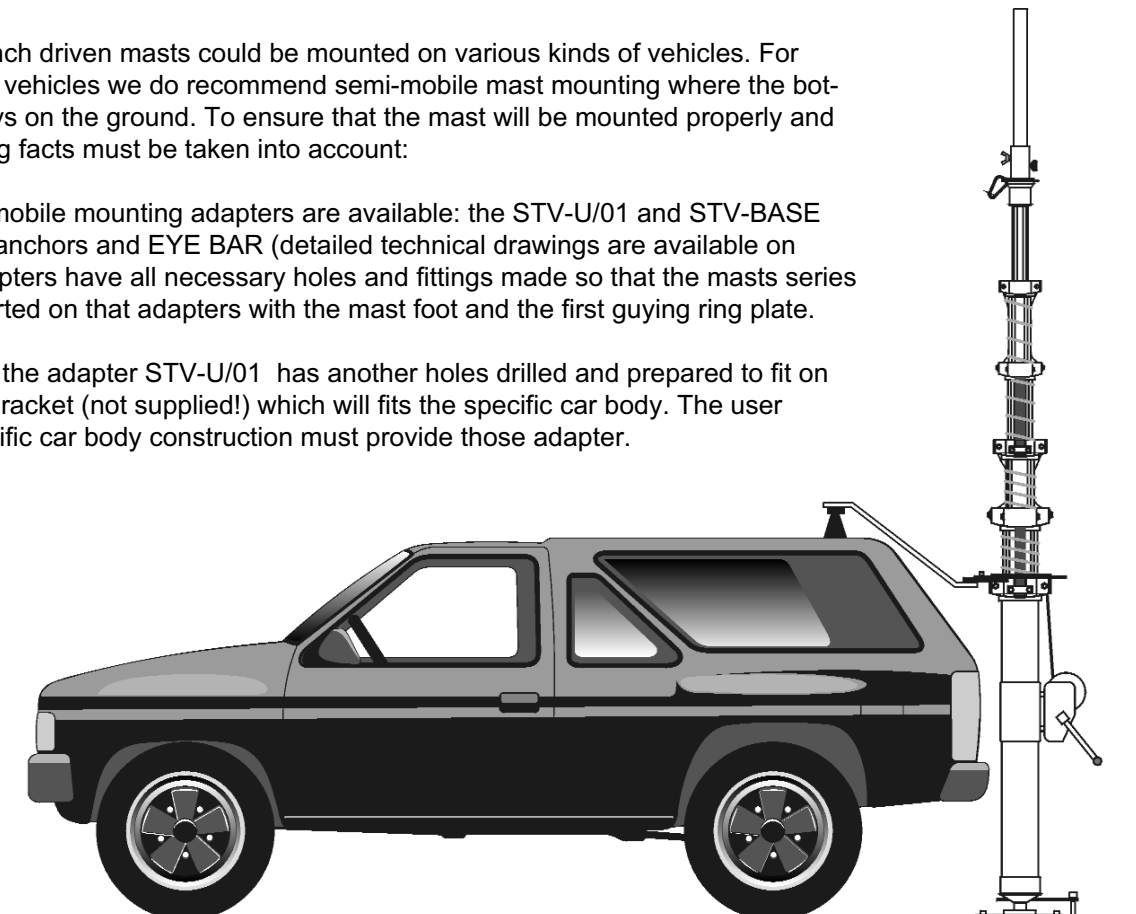

TECHNICAL SPECIFICATIONS	
System height (m)	8
Mast height (m)	7.5
Retracted length (m)	2.0
Bottom section diam. (mm)	105
Top section diam. (mm)	50
Extension tube length (mm)	500
Max. vertical top load (kg)	25
Max. wind area CxA (m ²)	0.50
Max. horizontal top load (N)	360
Max. operational wind speed (km/h)	120
Max. survival wind speed (km/h)	160
Guy radius (m)	7
No. of guys x levels	4 x 2
No. of sections	6
Mast weight (kg)	20.5
Accessories weight (kg)	24

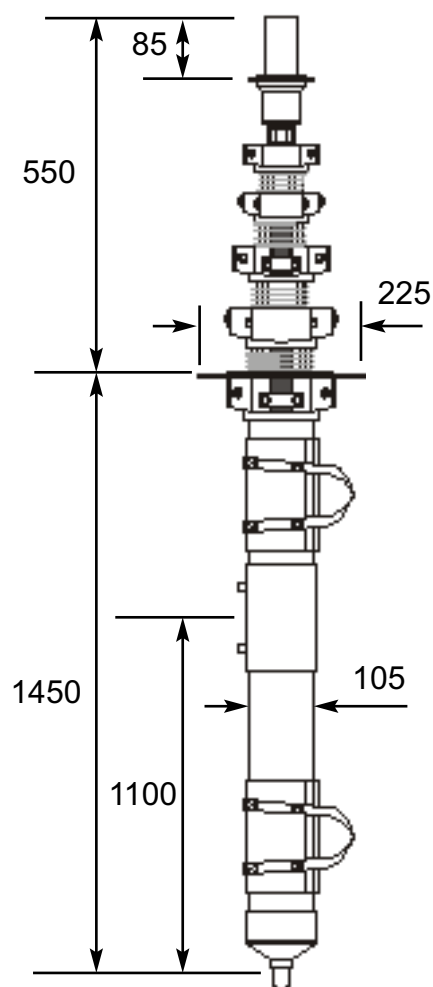
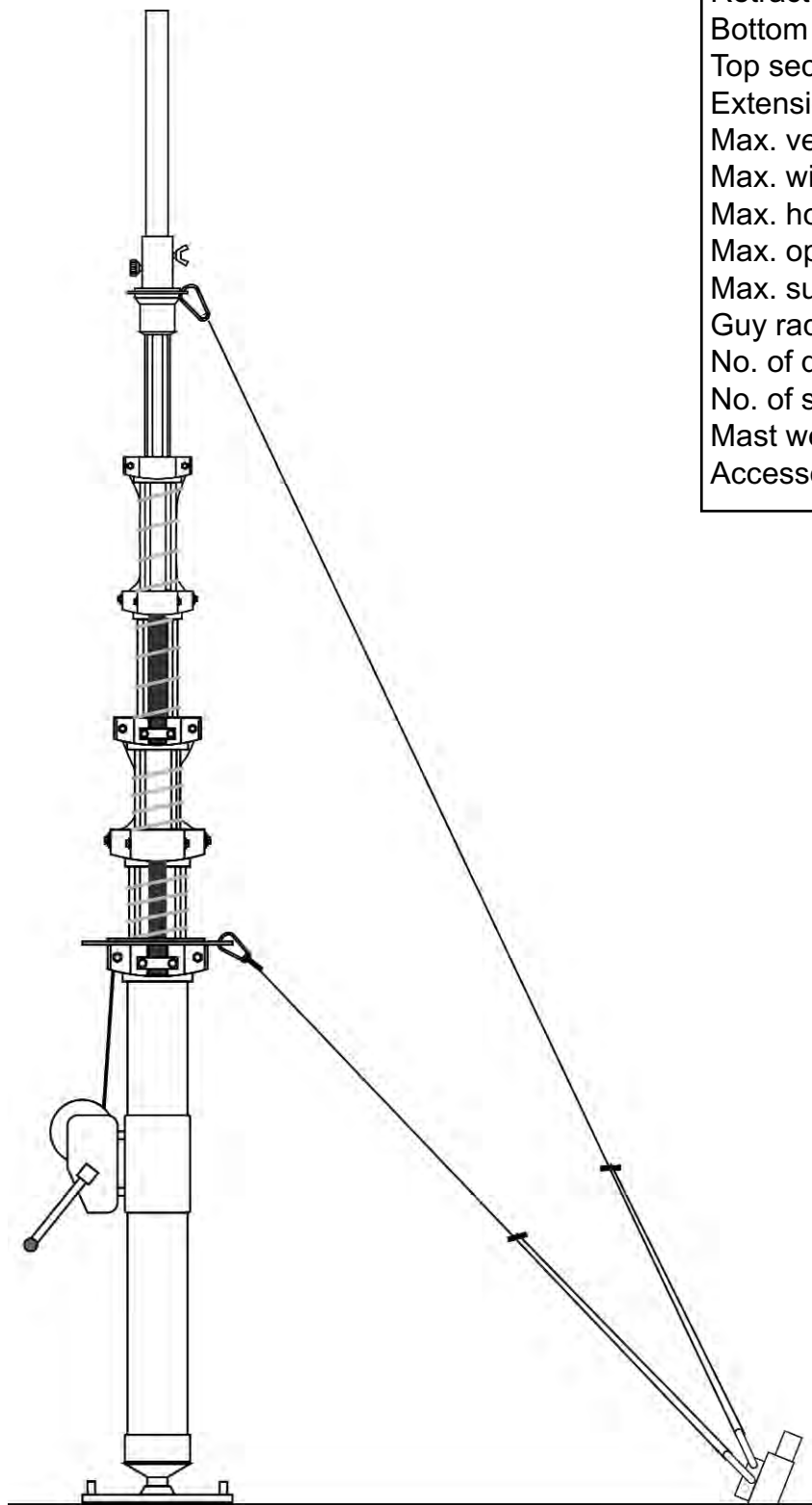

TECHNICAL SPECIFICATIONS	
System height (m)	10
Mast height (m)	9.5
Retracted length (m)	2.3
Bottom section diam. (mm)	105
Top section diam. (mm)	50
Extension tube length (mm)	500
Max. vertical top load (kg)	25
Max. wind area CxA (m ²)	0.35
Max. horizontal top load (N)	250
Max. operational wind speed (km/h)	120
Max. survival wind speed (km/h)	160
Guy radius (m)	7
No. of guys x levels	4 x 2
No. of sections	6
Mast weight (kg)	21.5
Accessories weight (kg)	24

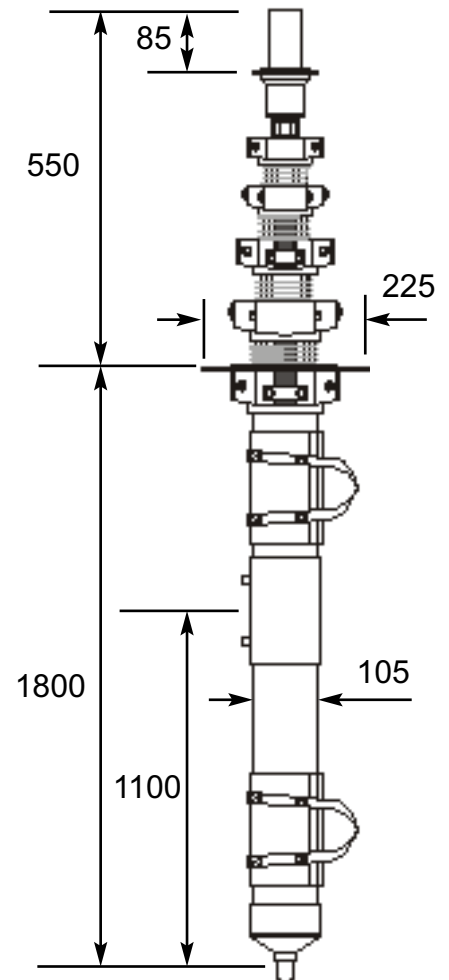
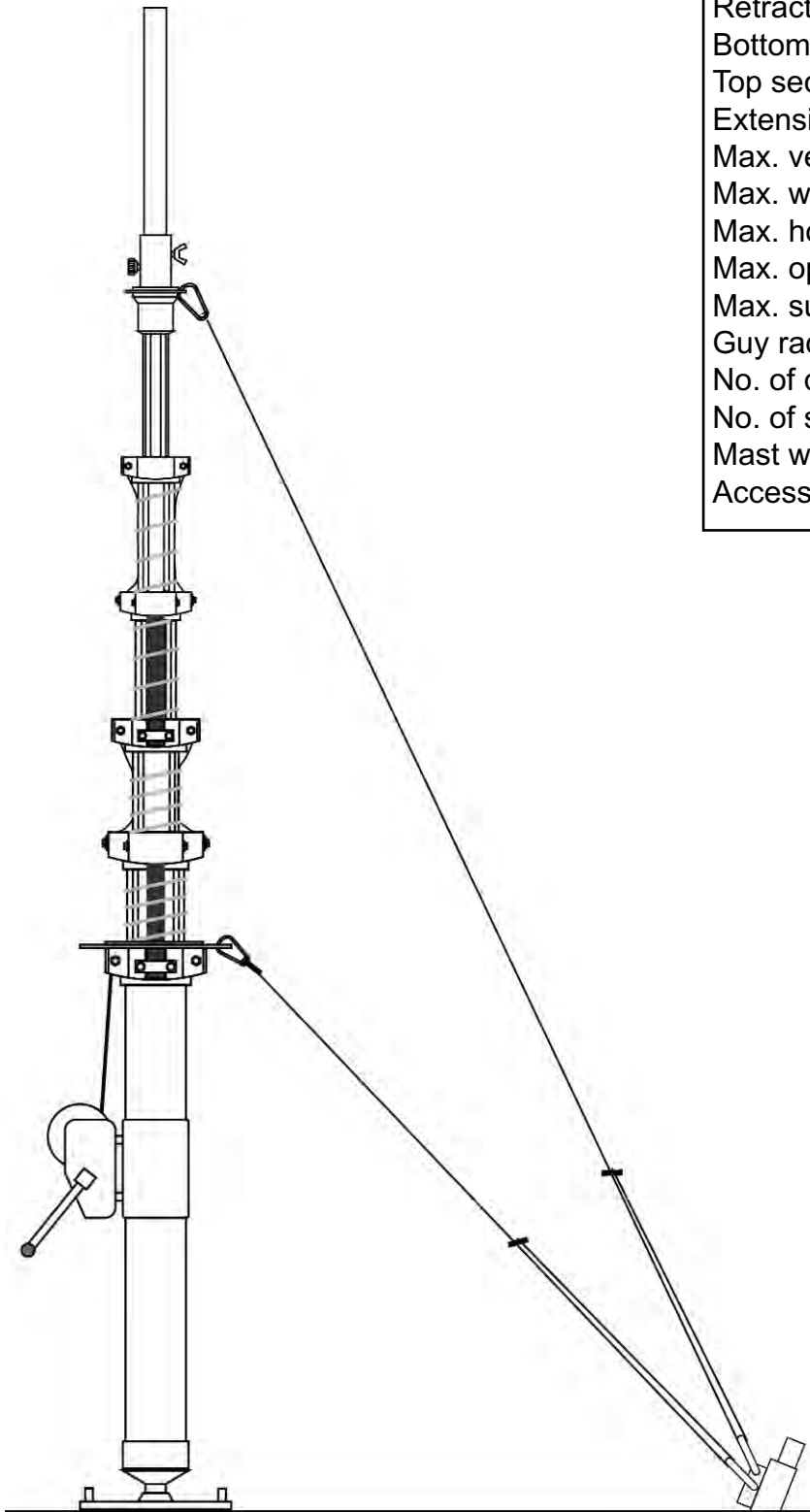

TECHNICAL SPECIFICATIONS	
System height (m)	12
Mast height (m)	11.5
Retracted length (m)	2.7
Bottom section diam. (mm)	105
Top section diam. (mm)	50
Extension tube length (mm)	500
Max. vertical top load (kg)	25
Max. wind area CxA (m ²)	0.4
Max. horizontal top load (N)	287
Max. operational wind speed (km/h)	120
Max. survival wind speed (km/h)	160
Guy radius (m)	8-10
No. of guys x levels	4 x 3
No. of sections	6
Mast weight (kg)	23
Accessories weight (kg)	34.7

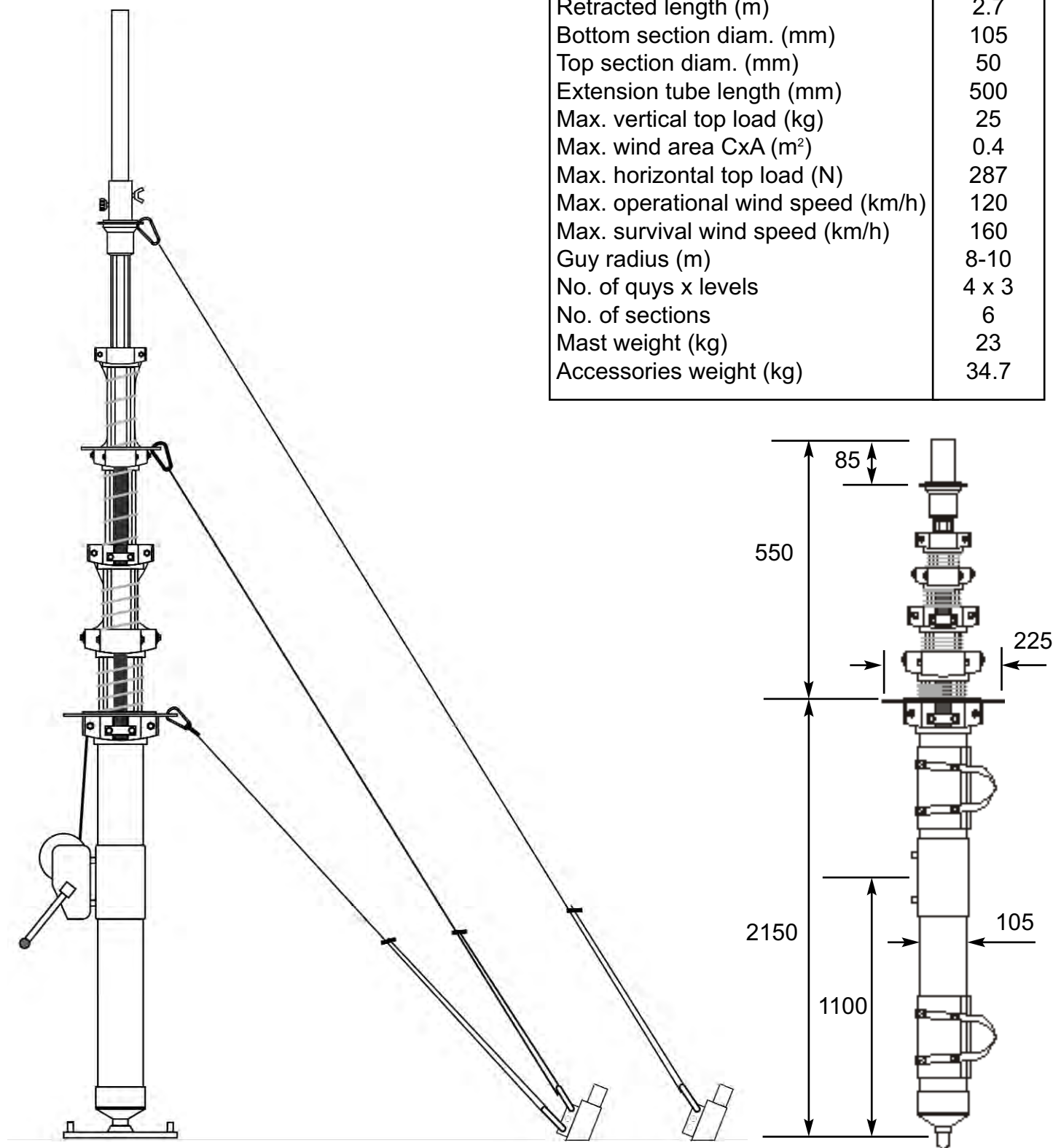

TECHNICAL SPECIFICATIONS	
System height (m)	15
Mast height (m)	14.5
Retracted length (m)	3.2
Bottom section diam. (mm)	105
Top section diam. (mm)	50
Extension tube length (mm)	500
Max. vertical top load (kg)	25
Max. wind area CxA (m ²)	0.35
Max. horizontal top load (N)	250
Max. operational wind speed (km/h)	120
Max. survival wind speed (km/h)	160
Guy radius (m)	10-12
No. of guys x levels	4 x 3
No. of sections	6
Mast weight (kg)	25
Accessories weight (kg)	36.5

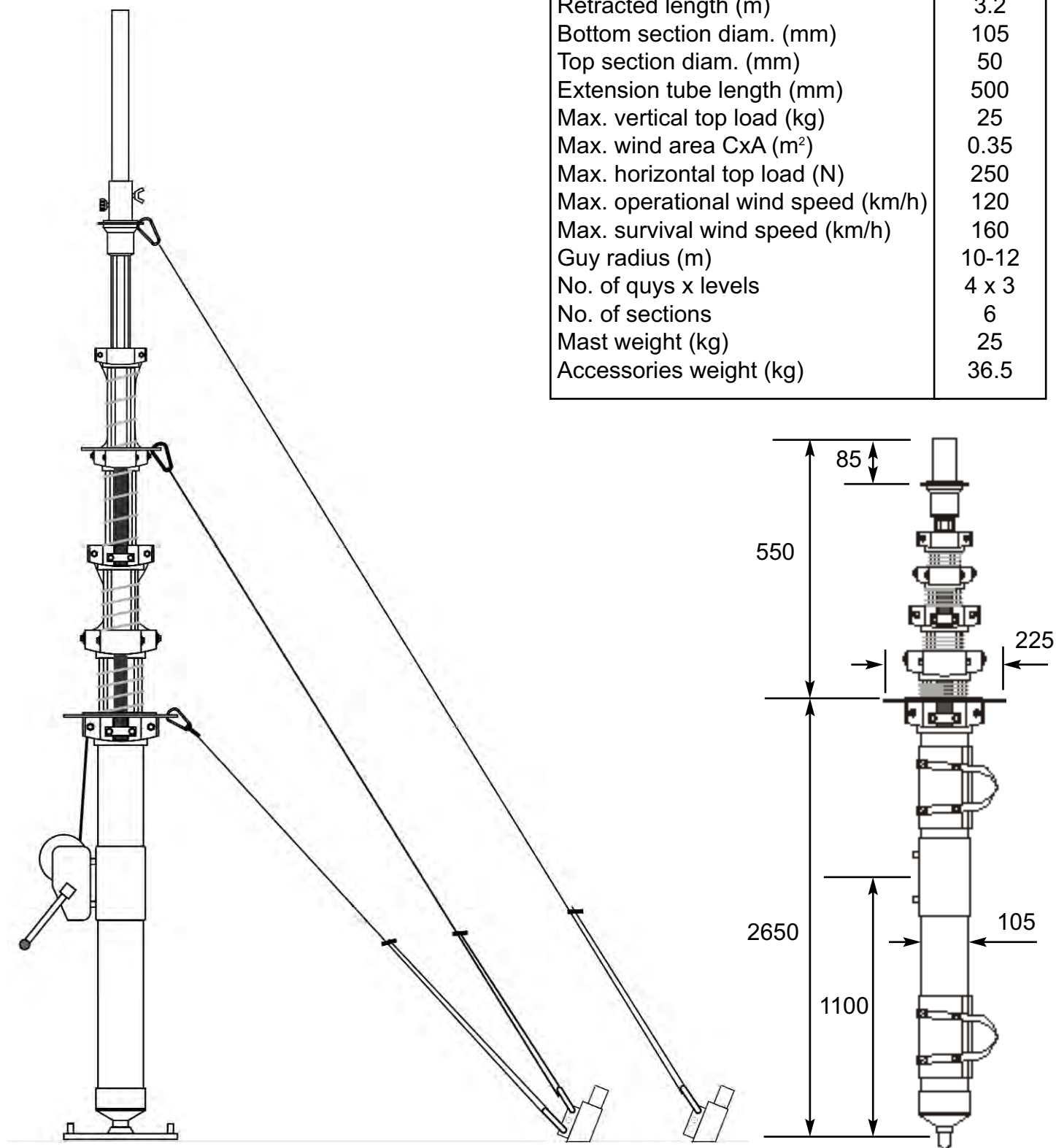

TECHNICAL SPECIFICATIONS	
System height (m)	8
Mast height (m)	7.5
Retracted length (m)	2.0
Bottom section diam. (mm)	128
Top section diam. (mm)	71.5
Extension tube length (mm)	500
Max. vertical top load (kg)	35
Max. wind area CxA (m ²)	0.80
Max. horizontal top load (N)	570
Max. operational wind speed (km/h)	120
Max. survival wind speed (km/h)	160
Guy radius (m)	7
No. of guys x levels	4 x 2
No. of sections	6
Mast weight (kg)	24.5
Accessories weight (kg)	27.5

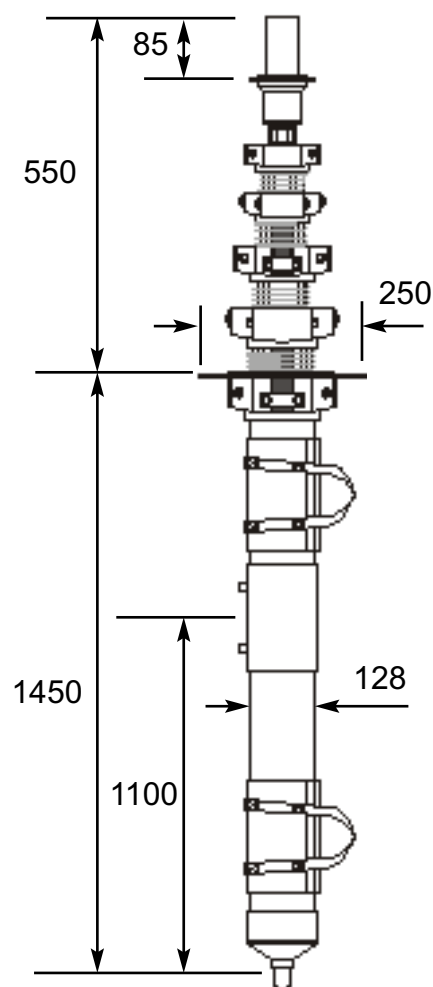
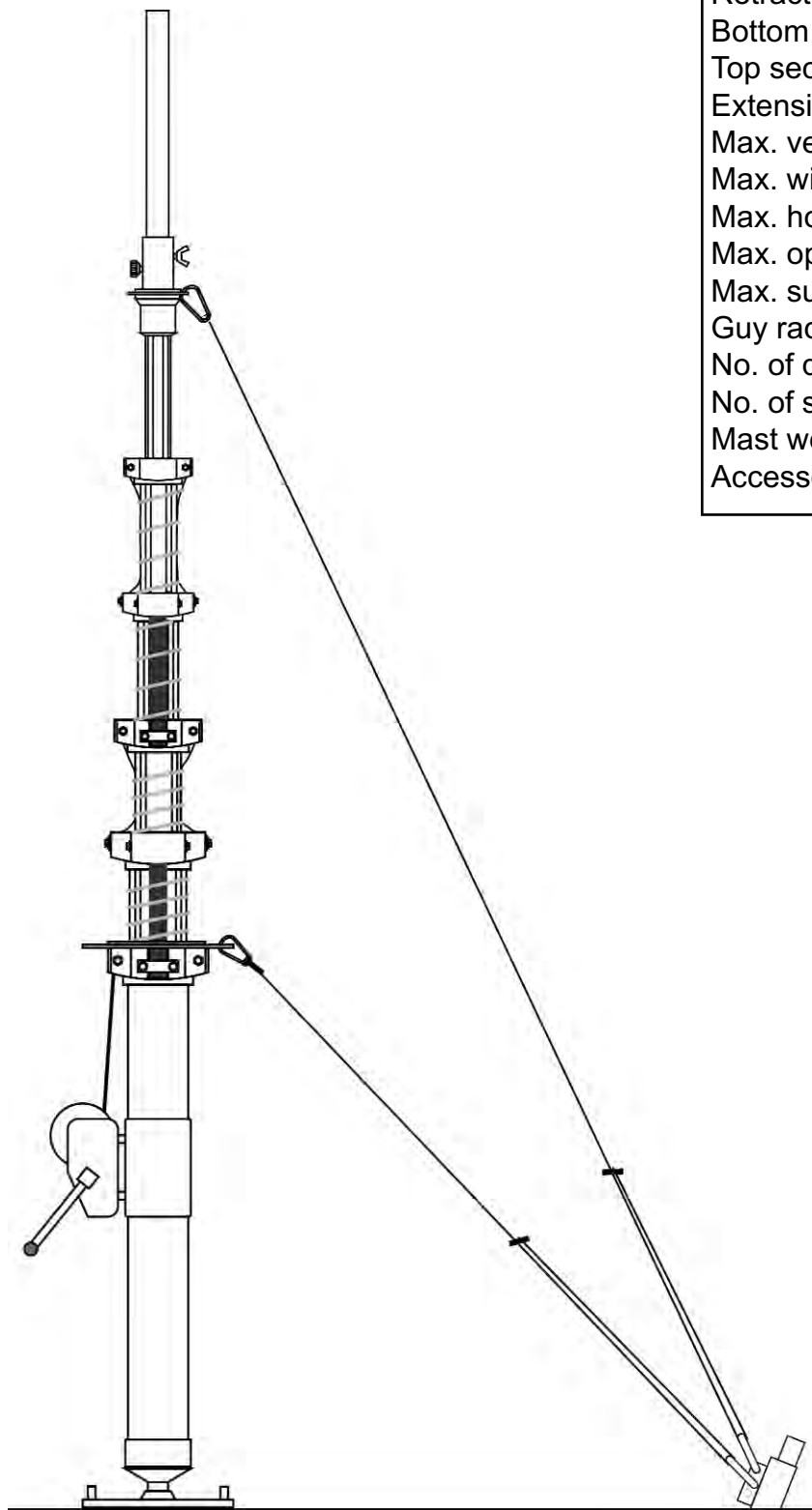

TECHNICAL SPECIFICATIONS	
System height (m)	10
Mast height (m)	9.5
Retracted length (m)	2.3
Bottom section diam. (mm)	128
Top section diam. (mm)	71.5
Extension tube length (mm)	500
Max. vertical top load (kg)	35
Max. wind area CxA (m ²)	0.70
Max. horizontal top load (N)	500
Max. operational wind speed (km/h)	120
Max. survival wind speed (km/h)	160
Guy radius (m)	7
No. of guys x levels	4 x 2
No. of sections	6
Mast weight (kg)	26.5
Accessories weight (kg)	27.5

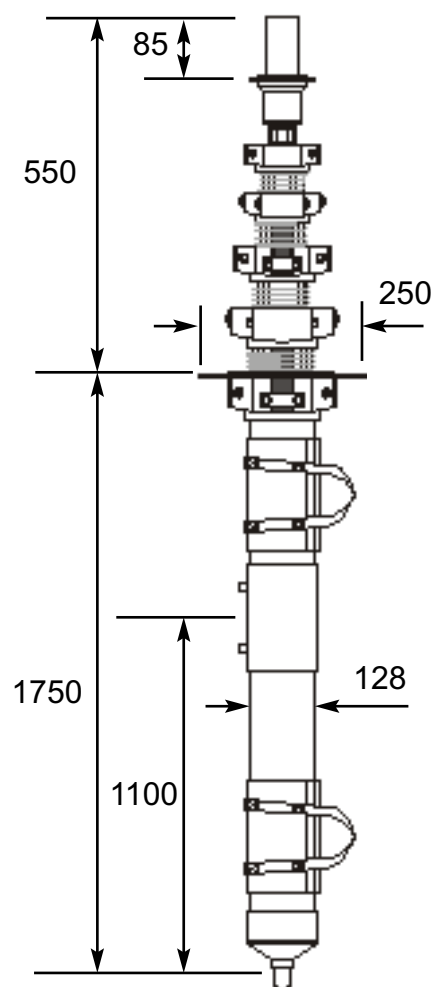
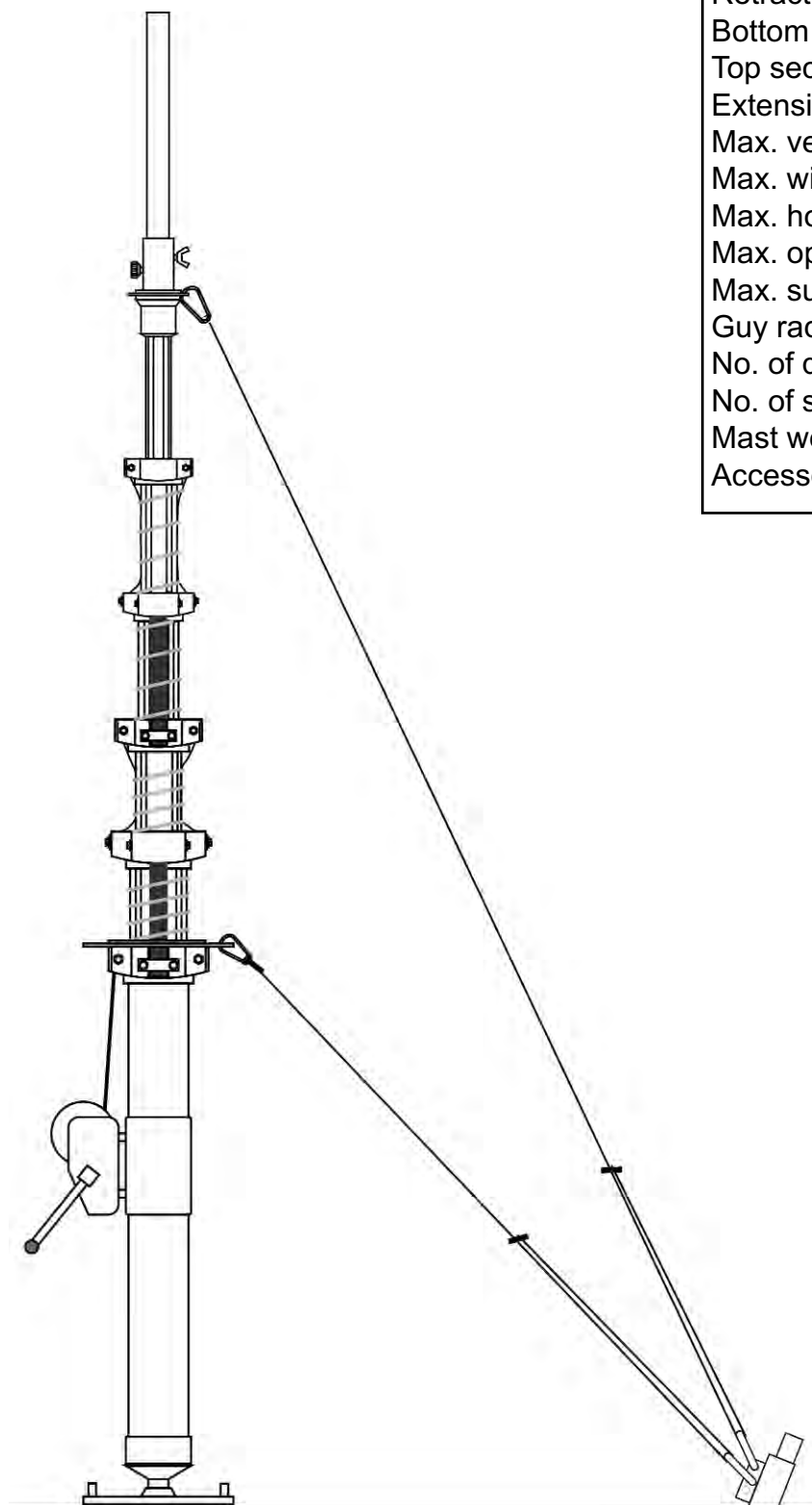

TECHNICAL SPECIFICATIONS	
System height (m)	12
Mast height (m)	11.5
Retracted length (m)	2.7
Bottom section diam. (mm)	128
Top section diam. (mm)	71.5
Extension tube length (mm)	500
Max. vertical top load (kg)	35
Max. wind area CxA (m ²)	0.8
Max. horizontal top load (N)	570
Max. operational wind speed (km/h)	120
Max. survival wind speed (km/h)	160
Guy radius (m)	8-10
No. of guys x levels	4 x 3
No. of sections	6
Mast weight (kg)	29
Accessories weight (kg)	38

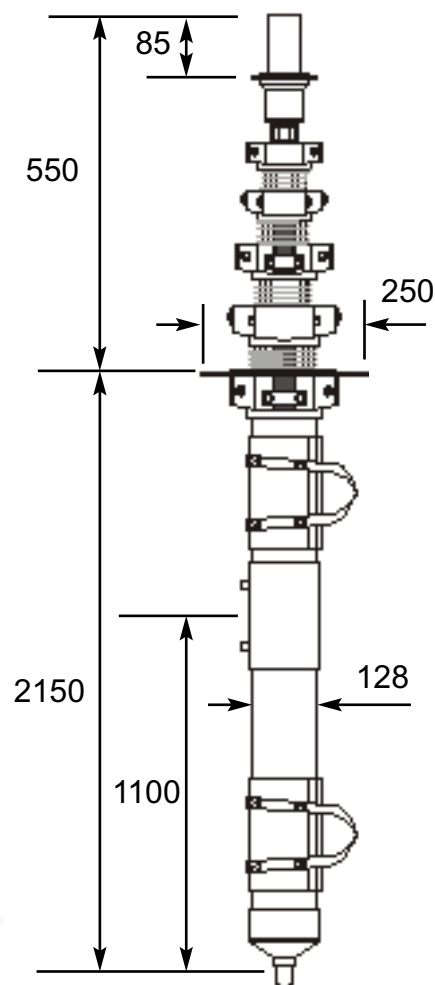
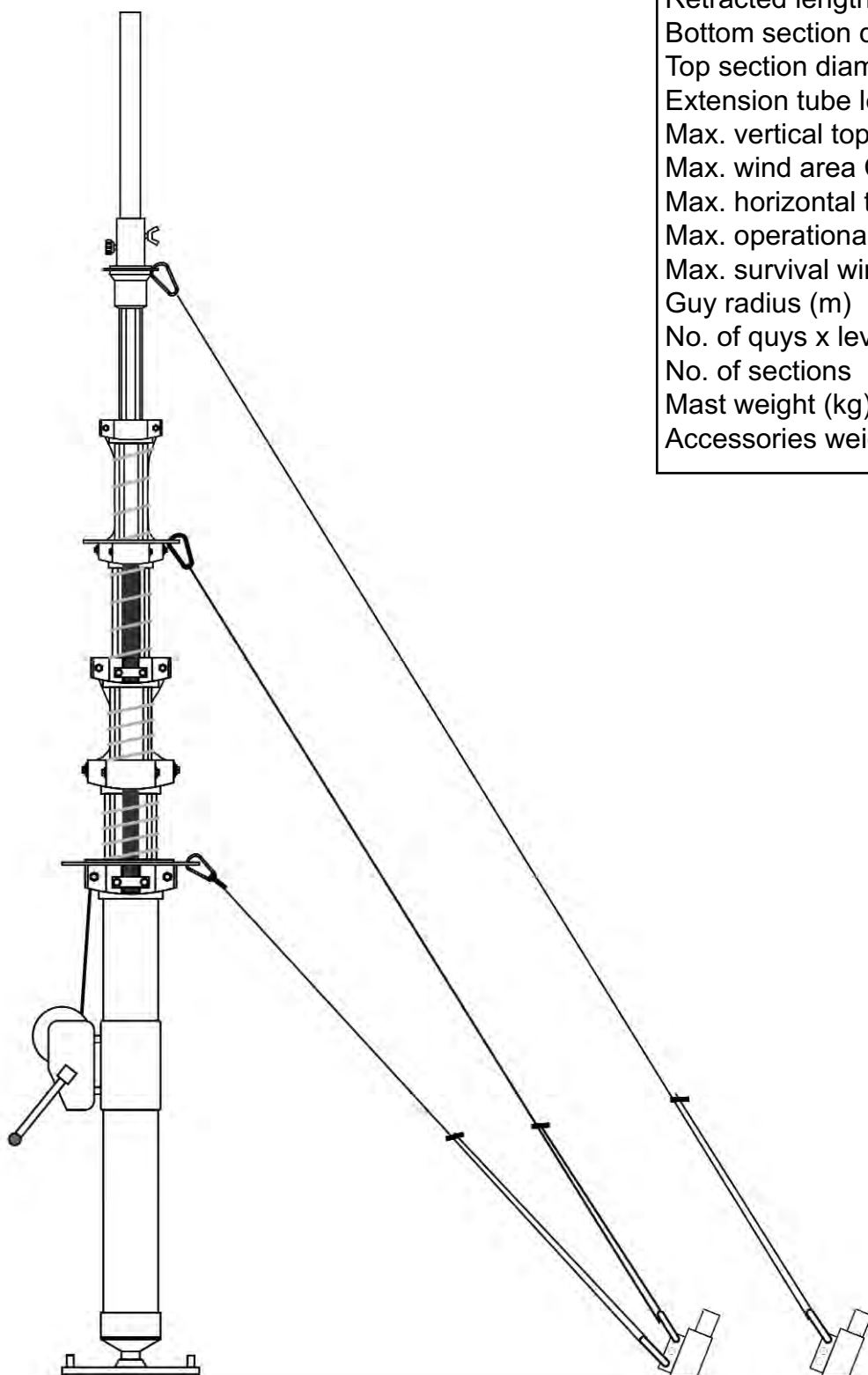

TECHNICAL SPECIFICATIONS	
System height (m)	15
Mast height (m)	14.5
Retracted length (m)	3.2
Bottom section diam. (mm)	128
Top section diam. (mm)	71.5
Extension tube length (mm)	500
Max. vertical top load (kg)	30
Max. wind area CxA (m ²)	0.8
Max. horizontal top load (N)	570
Max. operational wind speed (km/h)	120
Max. survival wind speed (km/h)	160
Guy radius (m)	10-12
No. of guys x levels	4 x 3
No. of sections	6
Mast weight (kg)	35
Accessories weight (kg)	44

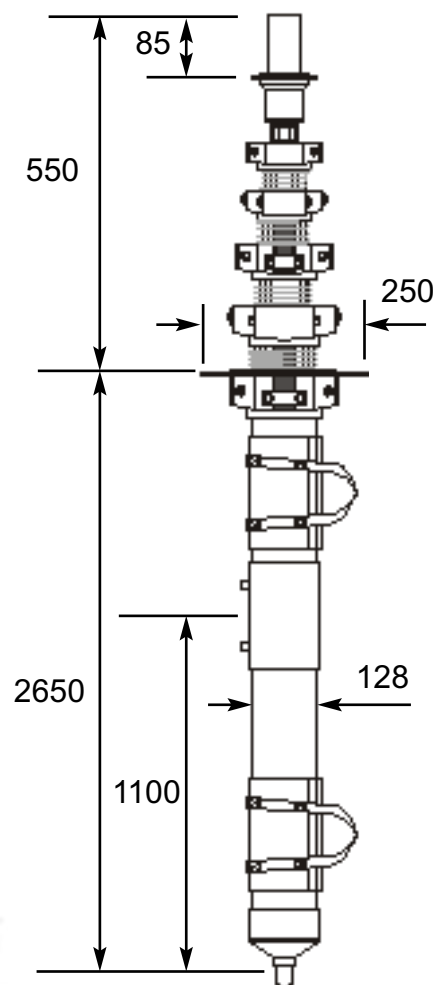
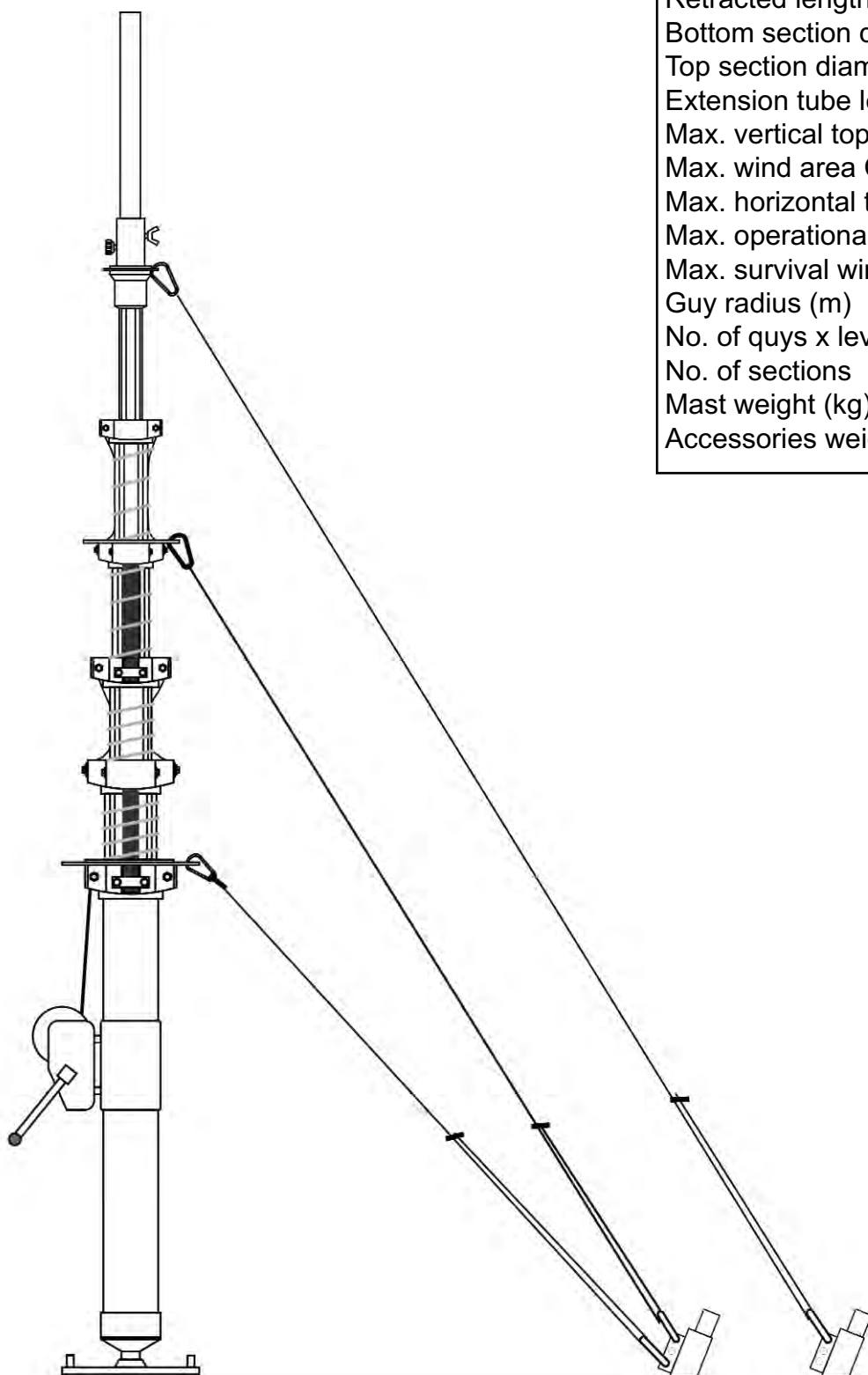

TECHNICAL SPECIFICATIONS	
System height (m)	18
Mast height (m)	17.5
Retracted length (m)	3.7
Bottom section diam. (mm)	128
Top section diam. (mm)	71.5
Extension tube length (mm)	500
Max. vertical top load (kg)	30
Max. wind area CxA (m ²)	0.6
Max. horizontal top load (N)	430
Max. operational wind speed (km/h)	120
Max. survival wind speed (km/h)	160
Guy radius (m)	10-12
No. of guys x levels	4 x 3
No. of sections	6
Mast weight (kg)	41.5
Accessories weight (kg)	44

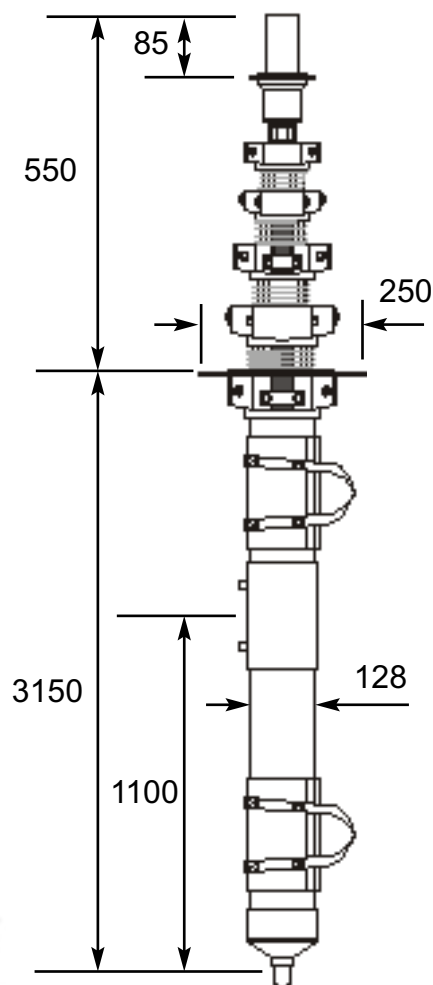
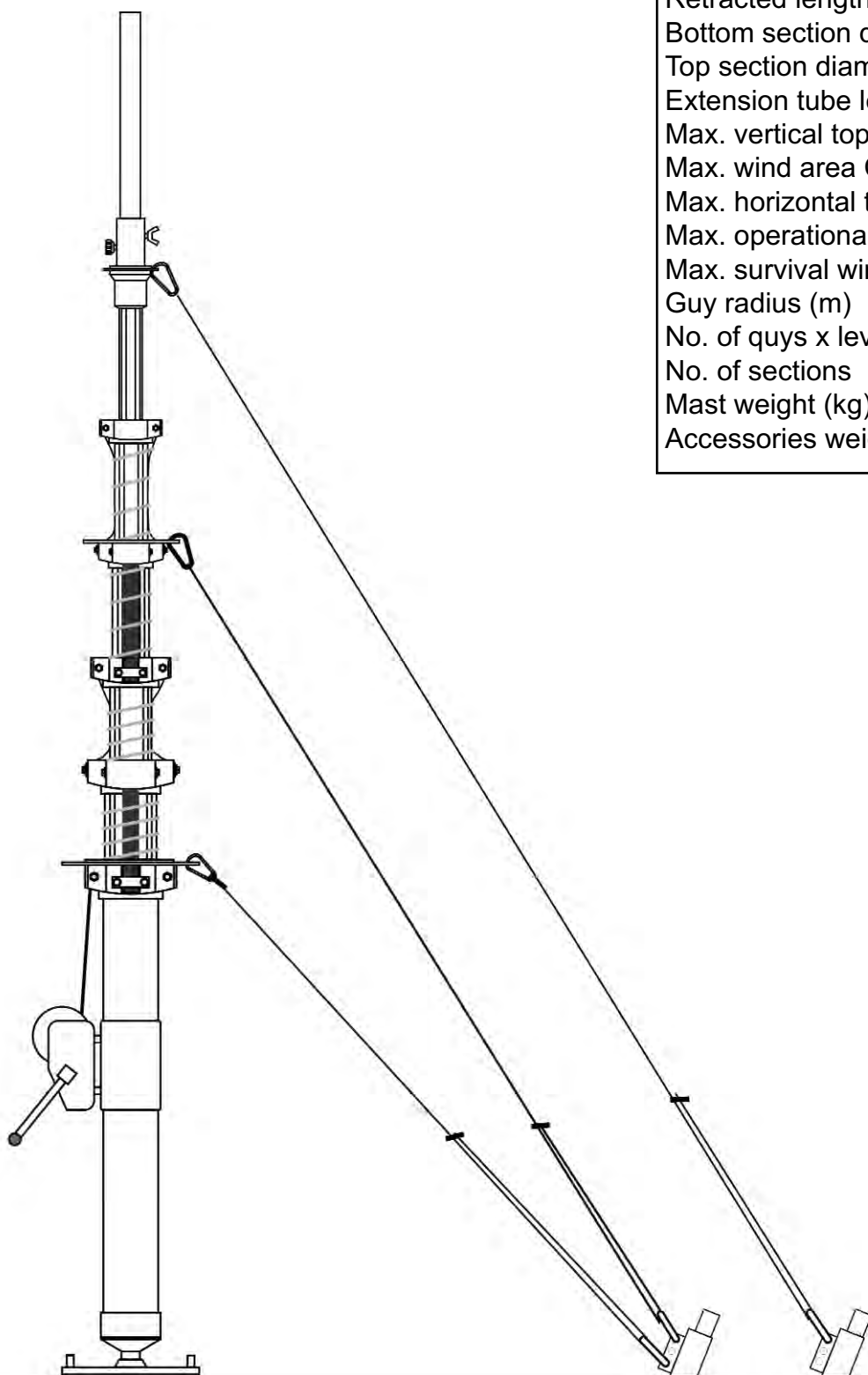

STV MAST ACCESSORIES

Extension tube 50/50



Bag



Winch 501



Base plate



Winch 651



Guying anchor



Eye bar



Base plate anchor

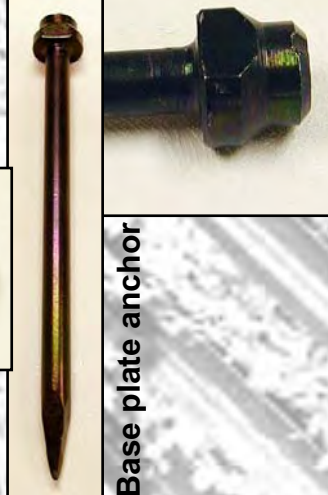

Hammer



Guying rope

